



Opti-Cal

Humidity Calibrator

From the Calibration Range

Stand-alone calibrator for rh sensors providing humidity and temperature profiling with an in-built, traceable cooled mirror reference hygrometer



*Opti-Cal
Humidity Calibrator*

Features

- Perform rh sensor calibrations in-house
- Simple and easy to use
- Fully self-contained system
- Digital control of temperature and relative humidity
- Range 10 to 90 % rh over 10 to 50 °C chamber temperatures
- Integrated traceable reference hygrometer
- Best measurement capability <2% of reading

Local, Traceable Humidity Calibrations

For the user of relative humidity sensors there is always a question over the calibration accuracy and stability of the instruments in use. % rh sensors provide economical measurement but require regular calibration and adjustment to ensure correct performance over extended time periods. It is common for such sensors to require calibration and adjustment at three or six month intervals, depending on the criticality of the measurement process.

Opti-Cal offers the opportunity to provide local calibration of such rh sensors, without the need to send them away to a traceable laboratory or incur the additional cost of contracted on-site calibration services. For a relatively low capital investment, Opti-Cal will provide calibrations that are directly traceable to International Standards over a wide relative humidity range, and at any set temperature from 10 to 50 °C*.

Integrated System

Opti-Cal is a portable, fully self-contained humidity/temperature calibrator. The system comprises a humidity/temperature controlled chamber that can house up to six or more humidity sensors, depending on their physical dimensions. Temperature and humidity within the chamber are closed-loop controlled and continuously monitored by a precision chilled mirror reference hygrometer. Opti-Cal works by time proportioning the flows of dry and saturated air according to the pre-selected relative humidity value. The chamber temperature is controlled by a four-zone Peltier heat pump arrangement for maximum stability and minimum temperature gradient. The saturator assembly can be filled easily with distilled water at the front of the unit and the easily accessible desiccator can be re-charged by heating when required. No other maintenance is necessary. The only external service required is a single phase power supply.

Easy set up and operation

Operation of Opti-Cal could not be easier. To set a particular combination of humidity and temperature, just select the required values on the front panel thumbwheels and let the instrument go. Typical response time to a humidity or temperature step change is ten minutes, although the humidity sensors under calibration may require a longer settling time. A digital output from the reference hygrometer can be connected to Opti-Cal's custom Operating Software to provide on-screen monitoring of the actual conditions, with chart recording and data logging facility. Alternatively, this data can be fed into an industry standard data-logging system along with information from the sensors under test. Humidity and temperature set points can also be initiated remotely via 0-10V impulse signals if preferred.

Accurate and Traceable

Four wire resistance thermometers for temperature and dew point measurement allow Opti-Cal to provide precise humidity and temperature reference data for the calibration of relative humidity sensors. System accuracy of +/- 0.2 °C dew point and 0.1 °C temperature, with a measurement uncertainty (achieved through UKAS calibration of the dew-point and temperature sensors) of around +/- 0.2 °C at k=2 means that an overall uncertainty to better than 2% of measured value is achievable. The in-built reference cooled mirror hygrometer may be calibrated traceable to UK and US national standards and can, optionally, be provided with UKAS certification giving conformity with EA and ILAC.

Note: For 2006, the Opti-Cal is now provided with a 6 point UKAS (ILAC) calibration free of charge

**MICHELL
Instruments**



The Dew Point Specialists

Please note: Michell Instruments is continually improving its products and services. Therefore, by the time you read this datasheet, the details contained on it may have been superseded. Please call us to ensure that you have the latest version.

© Michell Instruments 2006

Technical Specifications

CHAMBER

Control temp range	10 to 50 °C, +/- 0.2 °C
	*lowest temperature set point = 10 °C below ambient
Control humidity range	10 to 90 % rh
Temperature stability	+/- 0.1 °C
Humidity stability	+/- 0.5 % rh
Chamber heating rate	1.5 °C per minute, 20 °C to 40 °C
Chamber cooling rate	0.7 °C per minute, 40 °C to 20 °C
Humidity ramp rate	3% rh per minute
Chamber internal vol	2000 CM ³
Humidifier	Time modulated injection, uses distilled water
Desiccator	Re-chargeable, removable cartridge, uses silica gel or molecular sieve desiccant
Control input	0.1 step thumbwheels for temperature and %rh
Control element	Embedded rh sensor
Sensor access	Pre-drilled front plate or internal mounting with 25 pin D connector lead-through to front panel

REFERENCE HYGROMETER

Type	Michell Optidew Transmitter
Dew point accuracy	+/- 0.2 °C
Temperature accuracy	+/- 0.1 °C
	rh: +/-2% of measured value
Display	High definition 2 line alphanumeric, °C, °Cdp, %rh, g/kg, g/m ³ , (t-t _d), a _w , status information
Outputs	RS232, twin mA outputs configurable, alarm status

GENERAL

Dimensions	520W x 290H x 420D mm
Weight	15kg approx
Power Supply	88-264V ac

Application Software

Bundled with Opti-Cal is a Windows™ application software suite that allows the user to monitor, chart and log calibration reference data on a PC for later manipulation. The software also allows control of the reference hygrometer parameters for diagnosis and optimisation, and provides the capability to configure measurement units, analogue outputs and alarms.

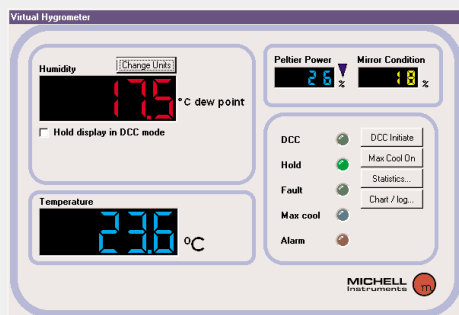

Application software

From the Calibration Range

Dimensions

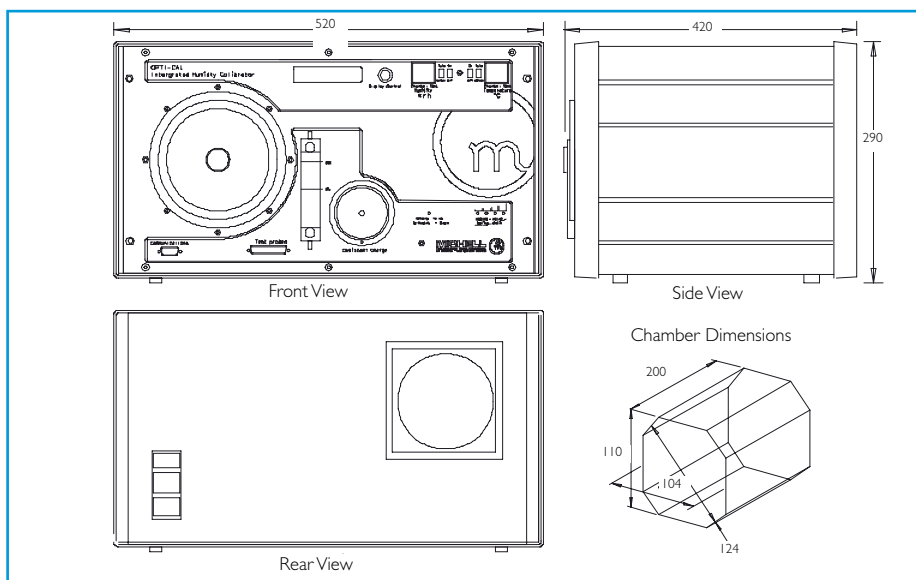

Dimensions mm

Opti-Cal - Ref: O/C-05-02

Michell Instruments Ltd
 Nuffield Close, Cambridge CB4 1SS UK
 Tel: +44 (0)1223 434800 Fax: +44 (0)1223 434895
 e-mail: info@michell.co.uk
 www.michell-instruments.com



Q6284 (UK)



0179 (UK)



MICHELL
 Instruments



The Dew Point Specialists